

LASER

Analogue Laser Displacement Transducer

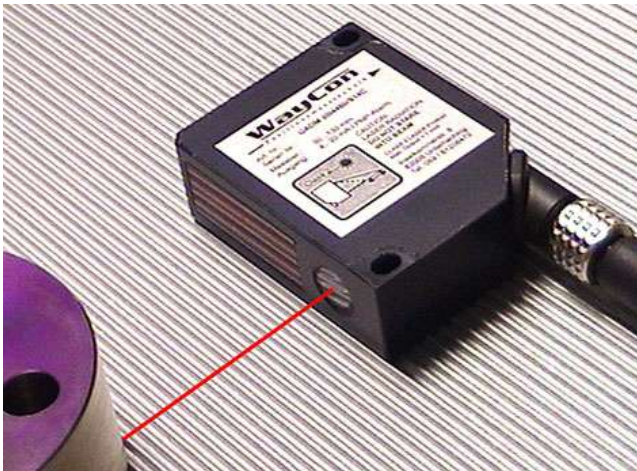

Series LAS LAM

- **Range 0,5 up to 800 mm**
- **Resolution up to 0,2 μm**
- **4...20 mA/ 0...10V analogue output and pnp-switch in one unit, RS485**
- **Spot or line beam**
- **Linearity $\pm 1 \mu\text{m}$**
- **Wavelength 675 nm**
- **Reverse polarity and short circuit protection (LAS-Series)**
- **Intelligent stand alone solution (no additional equipment needed)**
- **Protection class IP67**
- **Precise distance measurement on different surfaces**
- **Frequency response up to 40 kHz (LAM-Series)**
- **Working temperature up to 90° C**

Outline

LAS-Series

LAS-laser sensors cover a measurement range from 30 to 1000mm. The internal micro controller gives a precise output signal, which is proportional to the distance to be measured. No external electronic device is needed. An intelligent on-board signal conditioning unit enables the sensor to measure accurately on different target colours and surfaces.

The visible laser spot allows an easy and exact adjustment of the sensor. When target surfaces are rough, the laser beam can be widened to a fine line to average the received signal and ensure reliable results.

Principle

LAS-Series

The distance measurement is based on the triangulation principle: The laser beam hits the target as a small spot. The position of this spot is detected by the receiver. Then the sensor can measure the angle and calculate the distance to the target.

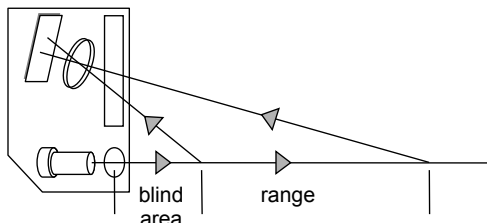

The possible resolution and accuracy change with the distance d : if d is close to the sensor, a greater angular change $a1$ is measured. If d is further from the sensor, a much smaller angular change $a2$ occurs (see sketch).

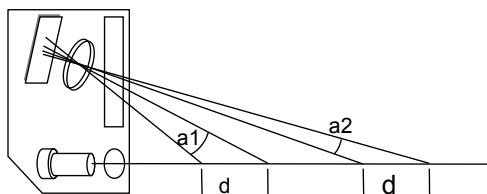

The receiver of the sensor is a photo diode array (a PSD element for faster response). The readout of the photo diode array is handled by an internal micro controller. The controller calculates the precise angle from the light allocation in the photo diode array. The exact distance to the target is calculated from the angle value. This distance is either transmitted to the serial port or converted into an output current which is proportional to the distance. The micro controller guarantees a high linearity and accuracy. The combination of photo diode array and micro controller allows a minimum of undesirable reflections. Thus a precise distance measurement is possible even on critical surfaces.

By changing the internal sensitivity, the sensor adapts to different colours and is therefore nearly independent from target colours.

In case of no target within the measurement range or insufficient light intensity, a digital output is activated (e.g. for pollution of the sensor).

Laser Beam Types

LAS-Series

Laser spot

The object is detected by a precisely focused laser beam.

This is the most popular type for LAS applications.

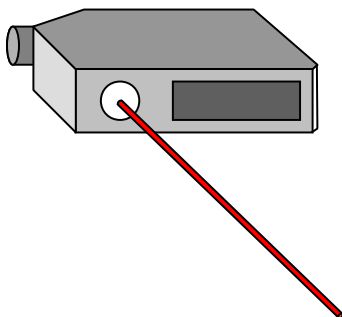

Laser line

The object is detected by a fine laser line.

Typically used for thickness- and position measurement on rough, porous surfaces.

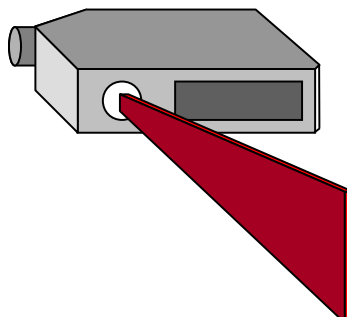

Technical data

LAS-Z



Wiring diagram 4...20 mA / 0...10 V *

+Vs	brown (1)
Alarm output	white (2)
GND	blue (3)
4...20 mA	black (4)
0...10 V	grey (5)

Wiring diagram RS485 (with K8P2M only)

Vin	brown
GND	blue
Switching output	yellow
Alarm output	grey
Rx/Tx+	pink
Rx/Tx-	white

*** Automatic output switch:**

Depending on the connected impedance in the output, the voltage or power supply is activated.

The output has to be wired up before connecting to the operating voltage.

Technical data

Typ	LAS-Z-20	LAS-Z-100	LAS-Z-120	LAS-Z-200	LAS-Z-400	LAS-Z-800
Range	30...50 mm	30...130 mm	200...320 mm	50...250 mm	100...500 mm	200...1000 mm
Resolution	0,01 mm	0,06 mm	0,2 mm	0,3 mm	0,5 mm	3 mm
Linearity	± 0,03 mm	± 0,2 mm	± 0,6 mm	± 0,9 mm	± 1,5 mm	± 12 mm
Response time	< 10 ms					
Sensing element	Photo diode array					
Alarm output	PNP					
Switching current	100 mA					
Power indicator	LED green					
Alarm indicator	LED red					
Pollution indicator	LED red flashing					
Supply	12 - 28 VDC					
Max. current	< 120 mA					
Light source	Laser diode, red, pulsed					
Laser class	2					
Wave length	675 nm					
Reverse polarity	Yes					
Short circuit prot.	Yes					
Housing material	Die-cast zinc					
Protection class	IP67					
Working temp.	0...+50°C					

Beam type

Spot laser (Ø)	1,0...0,4 mm	2,0...1,0 mm	2,0 mm	2,0 mm	2,0 mm	2,0 mm
Line laser						
Beam height	2 mm	3,0...5,0 mm	-	4,0...10,0 mm	5,5...18,0 mm	8,5...35,0 mm
Beam width	1,0...0,4 mm	2,0...1,0 mm	-	2,5 mm	2,5 mm	2,5 mm

Output

Analogue output	4...20 mA / 0...10 V, optional
RS 485	Optional (without analogue output)
Baud rate	Standard 19200 Baud
Start / stop Bits	1 start Bit, 1 stop Bit
Data length	8 Bits
Parity	None
Mode	Half duplex

The technical data (for linearity and response time) applies to a mat white object surface.

Technical data

LAS-TM/LAS-T (teach-in)



Wiring diagram 4...20 mA / 0...10 V

	LAS-T	LAS-TM
+Vs	brown (2)	brown (1)
n.c.	white (1)	
4...20 mA*	green (3)	black (4)
0...10 V*	pink (6)	
Alarm	grey (5)	
Teach-in	yellow (4)	white (2)
Synchro-in	red (8)	
0V	blue (7)	blue (3)

* Automatic output switch:

Depending on the connected impedance in the output, the voltage or power supply is activated.

The output has to be wired up before connecting to the operating voltage.

Technical data

Typ	LAS-TM-10	LAS-TM-104	LAS-T-40	LAS-T-250	LAS-T-500	LAS-T-800
Range	16...26 mm	16...120 mm	30...70 mm	50...300 mm	100...600 mm	200...1000 mm
resolution	0,002...0,005 mm	0,002...0,1 mm	0,004...0,02 mm	0,02...0,35 mm	0,03...0,6 mm	0,03...0,7 mm
Linearity	±0,006...±0,015 mm	±0,006...±0,35 mm	±0,012...±0,06 mm	±0,03...±1 mm	±0,05...±2 mm	±0,07...±2,5 mm
Min. teach-in range	1 mm	2 mm	2 mm	5 mm	10 mm	10 mm
Response time	<0,9 ms					< 10 ms
Sensing element	photo diode array					
Alarm output	-	-	FNP			
Sw itching current	-	-	100mA			
Pow er indicator	LED green					
Alarm indicator	LED red					
Pollution	LED red flashing					
Supply	12 - 28 VDC					
Max. current	< 100 mA		< 120 mA			
Light source	Laser diode red, pulsed					
Laser class	2					
Wave length	675 nm					
supp reverse polarity	yes					
Short circuit protectio	yes					
Housing material	Die-cast zinc					Aluminium
Protection class	IP67					
w orking temerature	0...+50°C					

Beam type

Laser spot (Ø ray)	0,5...0,2 mm	0,9...0,5 mm	1...0,2 mm	2,0 mm	2,0 mm	2,0 mm
----------------------	--------------	--------------	------------	--------	--------	--------

Output

Analogue output	4...20 mA	4...20 mA / 0...10 V, w ahlw eise
-----------------	-----------	-----------------------------------

The technical data (for linearity and response time) applies to a mat white object surface.

LAS-TM

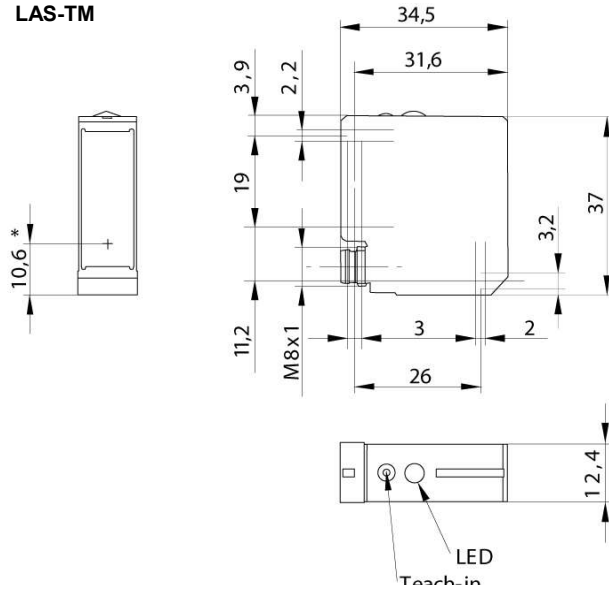

LAS-T-250/500
LAS-Z

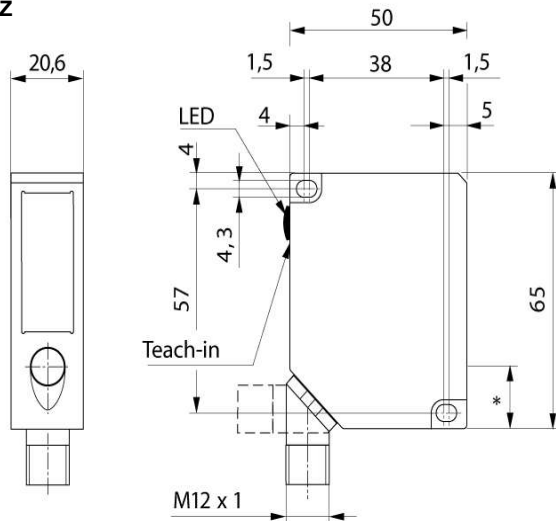

LAS-T-800

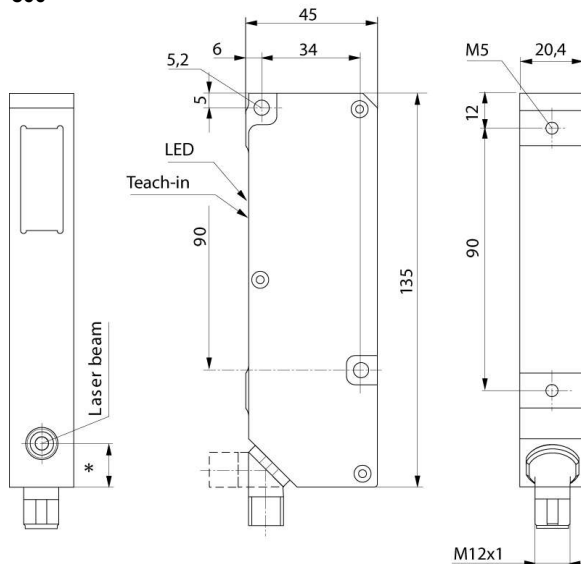

LAS-T-250-A

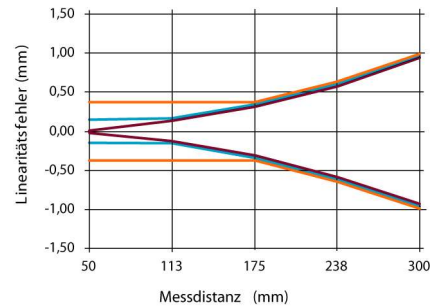
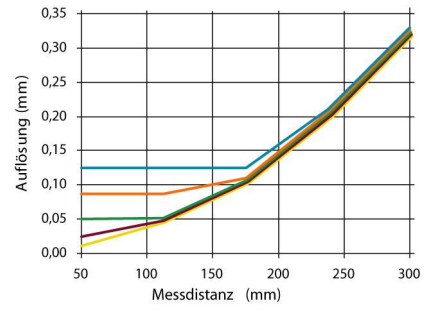

LAS-T-500-A

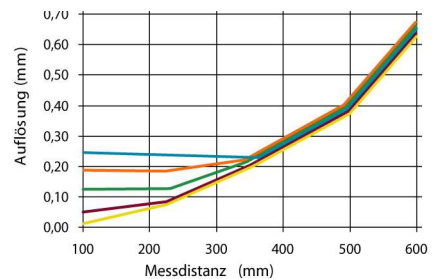
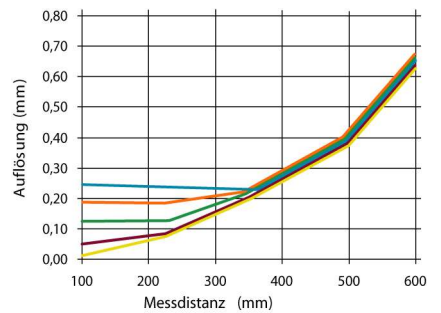



The optical distance sensor LAM is used in the field of non-contact measuring technology. The LAM distance sensors are manufactured for a wide range of specifications, so that for each application there is a suitable sensor available.

Due to the fast response time of the output signal (0,1 ms, down to 40 μ s on request) this series is particularly suitable for high dynamic measurements. The high resolution (down to 0,1 μ m) guarantees a reliable application for demanding measurements for quality control.

Description

LAM-Series

The optical displacement sensors of the LAM-series are designed for non-contact detection of the position or presence of objects. They measure the distance of objects according to the principle of **triangulation** in the range of 0,5 - 100 mm. The analogue output is a linear voltage representation of the deviation from the reference distance and has the range of ± 10 VDC, optional 0-10V, ± 5 VDC or 4-20 mA.

The reference distance corresponds to the middle of the measuring range. A light spot is focused on the object to measure. The sensor transmits pulsed light, thus the signal is mostly independent of ambient light.

The diffusely reflected light spot is directed to a PSD through a lens. The intensity of the light source is adjusted automatically, according to the reflectance of the surface.

If the intensity of the reflected light is too low, failure F1: "not enough light" is displayed.

Highly reflective surfaces, which reflect the transmitted light directly into the PSD, will lead to failure F2: "too much light". Both failures are displayed by separate LEDs and reported as logical output signals. As additional information on the lighting conditions a voltage output of the light intensity is available.

The output voltage "distance" at Pin 1 is directly proportional to the object distance. Distance limits for the object distance can be set with two comparators to distinguish between **too close / OK / too far**. LEDs display the present status with 3 optional relay outputs available.

Self test

A continuously running built-in mechanism guarantees the permanent monitoring of the intensity of the reflected light to check whether the object is located within the measuring range.

Response time and frequency range

The rise time of the output signal of the laser sensors is exceptionally fast. It averages to 100 μ s for the LAM to reach >90% of the final value (or 40 μ s on request). The rise/ integration time can be increased to 0.2 , 2 or 20 ms by DIP switches inside the electronic module. This reduces the noise level and improves the accuracy of the measurement. For a precise adjustment of this integration time both switches of the respective time have to be set on ON (see chart), all other switches on OFF.

Mounting the sensor head

To achieve optimal results it is important to mount the sensor in a 90° angle to the object surface, otherwise the path of the laser beam is elongated.

The LAM laser head should be mounted in such a way that the laser beam cannot be directed or reflected in the human eye. The visible warning label (included in delivery) should be installed close to the sensor.

To adjust the sensor the LEDs MIN, OK and MAX may be used.

At the delivery MIN and MAX values are preset on the measuring range limits. As long as the OK-LED is illuminated, the object is within the measuring range and reflects enough light.

The zero voltage adjustment should be done mechanically first, then, for fine tuning the zero-potentiometer R4 may be used, which can be adjusted with a screwdriver to approx. ± 5 % of the range.

For an alignment of the different slopes of the output characteristics due to specific object surfaces, the amplification-potentiometer R5 may be used.

Surface related measurement deficiencies

Impairment by materials and colours

The objects to be measured can be made of nearly all materials, e.g. metal, plastics, ceramics, rubber and paper. Only the application with highly reflective objects or liquids should be subject to special consideration.

Reflectance of the surface

The sensor needs a minimum diffuse reflection of 10% to perform correctly. Diffuse reflection only is usable for measurements.

Stray light

The projected light beam results in a small amount of stray light, which will be reflected by the object surface around the light spot and received by the sensor. Highly reflective surfaces around the light spot may cause the stray light to be directly reflected into the sensor and errors can occur.

Homogeneous surfaces with consistent reflecting properties do not cause such failures. If the shiny area is outside the light spot, failures are < 2%.

Penetration of the light beam into the object

Transparent plastic or cloudy liquids will allow the light beam to penetrate up to a certain depth, before being reflected. This depth has to be added to the measured distance and can only be verified by some additional experiments with the material.

Striped objects

For objects with light / dark stripes (e.g. wood) the sensor should be mounted with its optical centre line parallel to the stripes (see sketch). Due to their smaller light spot LAM / LASER sensors are most suitable for these applications.

Bright / dark contrast within the light spot

If there are surface areas with different reflectances joining at the light spot, the maximum light is not reflected from the centre of the spot and thus measurement errors may occur. However, this influence is minimised if the transition boundary lies parallel to the optical axis (see sketch).

Changes in reflection intensity during measurement

The amount of light emitted from the LAM will automatically be adjusted to the reflective properties of the materials.

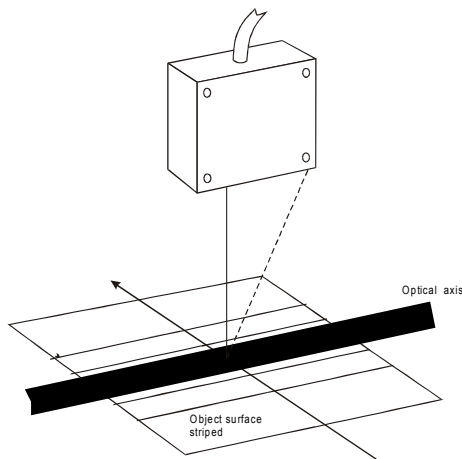

Angle dependence of measurements

There is a small angle dependence if the sensor is not mounted at right angles with the object surface. This dependence is very small for mat surfaces with high diffuse reflection and slightly greater for shiny surfaces.

An off-axis angle from axis A of up to 30° does not result in a significant measurement error, from axis B a rotation of up to 15° is possible.

The measurement error arises as a changing of the relationship between output voltage and distance. If the angle of rotation is constant, it can be eliminated by readjusting the values.

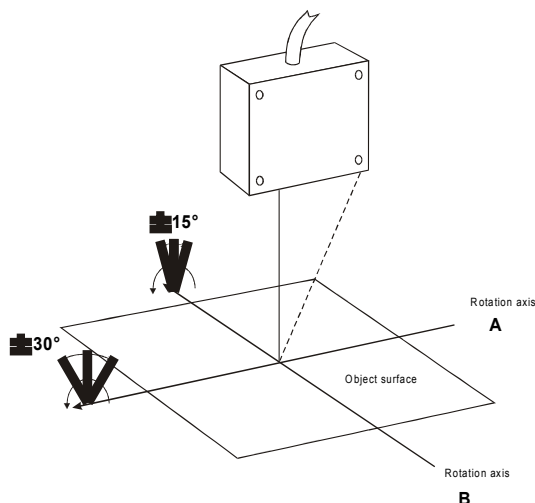

Technical data

LAM-Series

Type	LAM-0,5	LAM-2	LAM-10	LAM-20	LAM-50	LAM-100
Range	23,75...24,25 mm	23...25 mm	40...50 mm	55...75 mm	95...145 mm	170...270 mm
Resolution	0,2 µm	0,4 µm	5 µm	9 µm	30 µm	60 µm
Linearity	± 1 µm	± 4 µm	± 20 µm	± 40 µm	± 100 µm	± 200 µm
Response time	0,1 ms; 0,14 ms; 0,25 ms; 1 ms; 4 ms; 10 ms; 40 ms; 67 ms					
Sample frequency	54 kHz					
Switching output	MIN (LED yellow); MAX (LED orange); OK (LED green); 24 V / 10 mA					
Current consumption	10 mA (not available for Relay option)					
Power indicator	LED green					
Alarm indicator	LED red (too much light)					
Reflected light	0 V to 10 V					
Power supply	24 VDC / 200 mA (10 bis 30 V)					
Humidity	up to 90 % RH					
Light source	Laser diode, red, pulsed					
Laser class	2					
Wave length	670 nm					
Isolation voltage	200 VDC, 0 V ground to housing					
Max. vibration	5 g to 1 kHz (20 g optional)					
Housing material	Aluminium					
Protection class	IP64 (sensor) IP40 (electronics)					
Working temperature	0...+50°C					

Beam type

Spot laser (Ø)	0,1 mm	0,2 mm	0,6 mm	0,9 mm	1,5 mm	1,5 mm
----------------	--------	--------	--------	--------	--------	--------

Output

Analogue output	±10 V; 4 - 20 mA; RS232
Impedance	approx. 0 Ohm
Temp. coefficient	0,02% / ° K
External electronics	inclusive

The technical data (for linearity and response time) applies to a mat white object surface.

Pin connection electronic module

LAM with 24V output

Pin	
1	Distance output, ±10V
2	Not enough light, +24V/ 10 mA
3	Laser OFF, 0 V
4	TXD
5	Range OK, output, +24V/ 10 mA
6	4 – 20 mA
7	RXD
8	0 V supply
14	Analogue output GND
16	MAX, +24V/ 10 mA
17	Sensor 2, input
18	RTS
19	MIN, +24V/ 10 mA
20	Light intensity 0-10V
21	+24 V supply

Connector type: 25pin D-connector

Dip-switches

SW1	Function			
On	RS 232 Software Trigger with RXD			
Off	durationmode Stopp with RTS			
SW2	Function			
On	RS 232 transfer rate = 38,4 kBaud			
Off	RS 232 transfer rate = 115,2 kBaud			
SW3	out of use			
SW4	SW5	SW6	F/ kHz	T/ ms
On	on	on	10	0,1
Off	on	on	7	0,14
On	off	on	4	0,25
Off	off	on	1	1
On	on	off	0,25	4
Off	on	off	0,1	10
On	off	off	0,025	40
Off	off	off	0,015	67
SW7	SW8	Function		
On	on	normal-laser off, if I / 0 = GND		
Off	on	Trigger with I / 0 = GND		
On	off	Sensor = Master		
Off	off	Sensor = Slave		
Adjustment 4 kHz				

Sensor head type 50 / 100

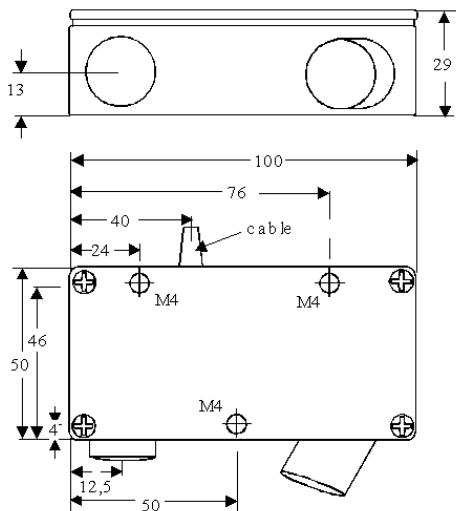

Sensor head type 2 / 10 / 20

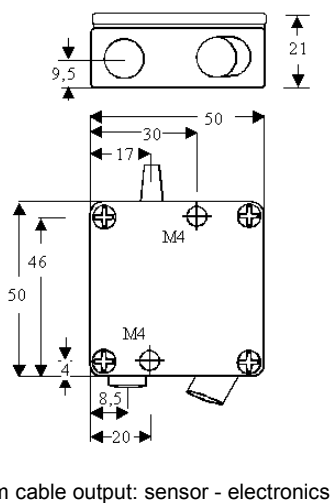

Sensor head type 0,5

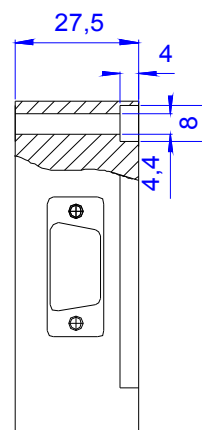
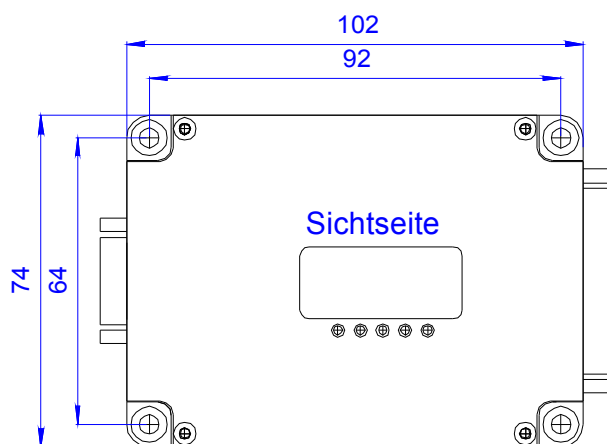
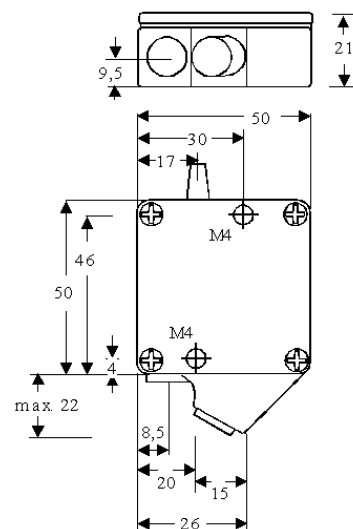

LAM-SG-S1

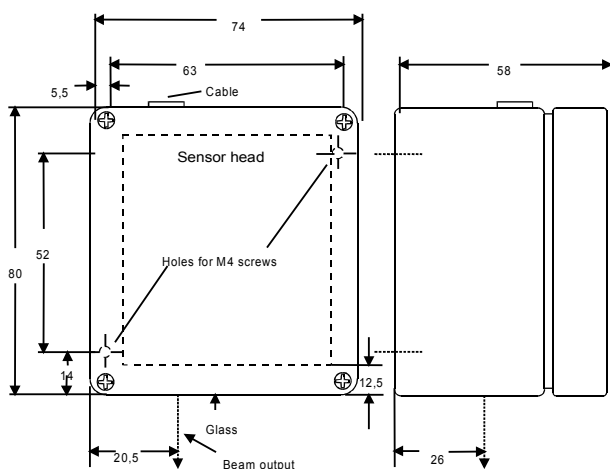

LAM-SG-T1

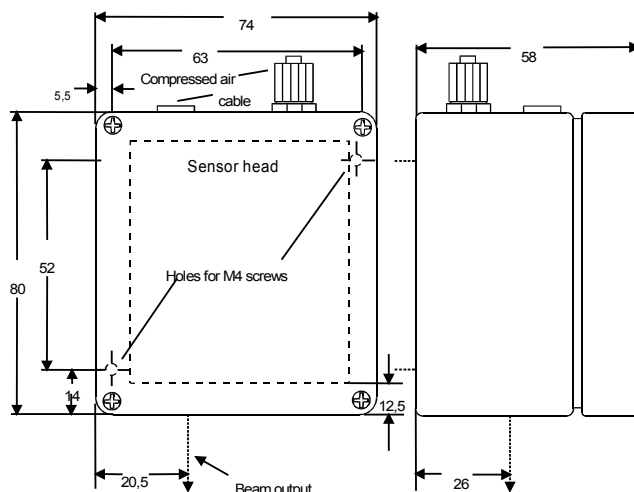

LAM-SG-S2

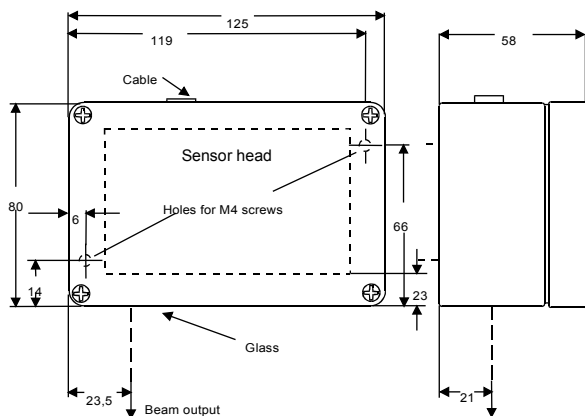

LAM-SG-T2

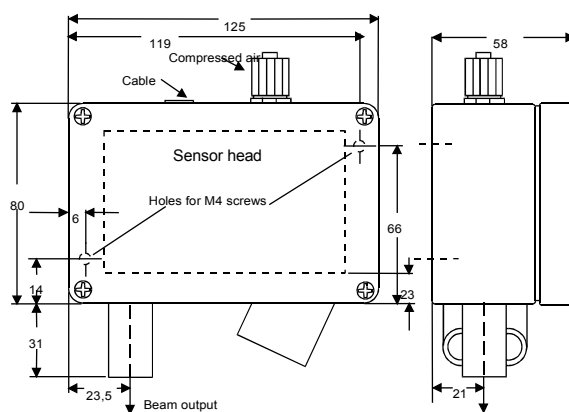

Protection housing for LAM sensors

For applications at a high pollution level or temperatures over 50°C a protection housing should be used. There are housings with an air cooling system with an airstream that prevents any dust from entering through the shelter opening.

LAM-SG-S1

Protection housing for LAM-2/10 with scratch resistant glass window for applications at a high pollution level

LAM-SG-S2

Protection housing for LAM-50/100 with scratch resistant glass window for applications at a high pollution level

LAM-SG-T1

Protection housing for LAM-2/10 with air connection for temperatures up to 50°C

LAM-SG-T2

Protection housing for LAM-50/100 with air connection for temperatures up to 50°C

Order code

LASER-Series

Fast laser with high resolution:

Range	
23,75...24,25 mm	0,5
23...25 mm	2
40...50 mm	10
55...75 mm	20
95...145 mm	50
170...270 mm	100

Output voltage	
-10/10 V	10/10
10 V (0...10 V) optional	10V
420 A (4...20mA) optional	420A

LAM — □ — □ — □

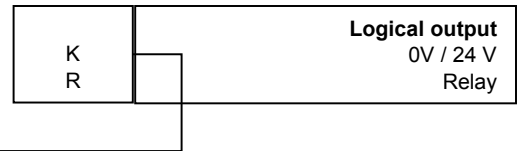

Laser with high resolution:

Type	
Spot laser	Z
Line laser	L

Range (spot and line laser)	
30...50 mm	20
30...130 mm	100
200...320 mm*	120
50...250 mm	200
100...500 mm	400
200...1000 mm	800

LAS — □ — □ — □



* LAS-Z-120 available in option A only

Options

LAS-L-XX
RS485

Linienlaser
LAS-Z / L-XX-RS485

- 5-polige Kabeldose inkl. 2 m Kabel
- 5-polige Kabeldose inkl. 5 m Kabel
- 8-polige Kabeldose inkl. 2 m Kabel
- 8-polige Kabeldose inkl. 5 m Kabel

We reserve the right to alter the specification without prior notice

WayCon Positionsmesstechnik GmbH
e-mail: info@waycon.de
internet: www.waycon.de

Head Office
Mehlbeerenstr. 4
82024 Taufkirchen
Tel. +49 (0)89 67 97 13-0
Fax +49 (0)89 67 97 13-250

Office Cologne
Auf der Pehle 1
50321 Brühl
Tel. +49 (0)2232 56 79 44
Fax +49 (0)2232 56 79 45